



THE STANDARD IN PV MOUNTING STRUCTURES™



Series 5004 and 5014

Double Row 6-Inch Pole Top with SolarMount® HD Rails

Installation Manual 507.6

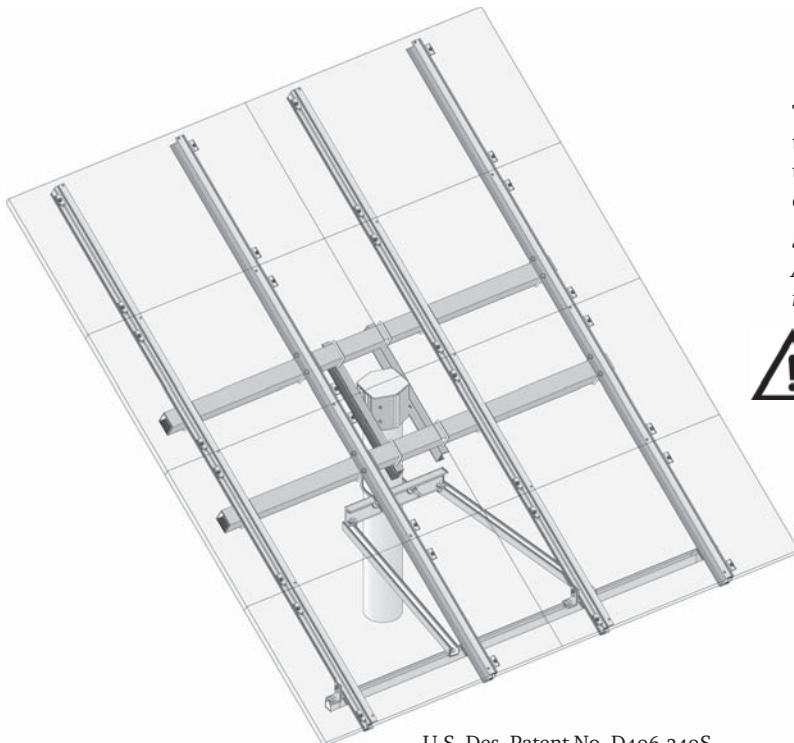

U.S. Des. Patent No. D496,249S.
Other patents pending.

Thank you for purchasing a UniRac product. Please review this manual completely before proceeding. This rack mounts to a 6-inch (150 mm) Schedule 40 or 80 steel pole, outside diameter 6.625 inches (168.3 mm).

Series 5014 models include a high wind brace (illustrated above). All Series 5004 models accommodate the high wind brace (item no. 990365) as an option.



The installer is solely responsible for:

- complying with all applicable building codes, including any that supersede these instructions;
- pole installation appropriate for local wind and soil conditions;
- using only UniRac parts and installer-supplied parts as specified by UniRac (substitution of parts will void the warranty);
- installing all electrical aspects of the PV array.

Basic Parts List for All Models

(Parts are illustrated on pp. 2–3).

Part	Qty	Wrench size	Recommended torque, ft-lbs (N-m)
Can and strut assembly (p. 3)			
Pole can, 6"	1		
Pole can set screws, square head, 3/8" x 1"	4	7/16", 12-point socket	25 (32)
Tilt strut, left	1		
Tilt strut, right	1		
Strut plate	2		
Hex bolt, 3/8" x 9"	1		
Carriage bolt, zinc plated, 3/8" x 1 1/2"—Grade 5	6	9/16"	35 (46)
Fender washer, 3/8" x 1 1/2"	6		
Fender washer, 3/8" x 1"	6		
Mechanical lock nut, 3/8"	7		varies
Rail and cross tube assembly (p. 4)			
SolarMount HD rail	4		
Square cross tube, 3"	2		
Square U-bolt, 3/8" x 3"	12		
Plate washer	12		
Flange nut, 3/8"	24	9/16"	30 (40)
Module mounting (p.5)			
Module mounting clip	4*		
Module bolt, 1/4" x 5/8"	4*	7/16"	15 (20)
Flat washer, 1/4"	4*		
Flange nut, 1/4"	4*	7/16"	15 (20)

* Per module to be mounted. Series 5014 and 5004 racks include clips and hardware to mount from 4 to 12 modules, depending on the model number.

High Wind Brace Parts List *(Included with Series 5014 and models.*

Optional with Series 5004 models. (Parts are illustrated on p. 4).

Part	Qty	Wrench size	Recommended torque, ft-lbs (N-m)
Pole bracket	1		
Leg strut, 75"	2		
Rail strut, 106"	1		
L-foot	4		
U-bolt, 3/8" x 6 5/8"	1		
Hexhead bolt, 3/8" x 3/4"	4	9/16"	30 (40)
Hexhead bolt, 3/8" x 1 1/4"	8	9/16"	30 (40)
Flat washer, 3/8" x 1 1/4"	8		
Strut nut, 3/8"	8		
Flange nut, 3/8"	6	9/16"	30 (40)

Stainless steel hardware can seize up, a process called galling. To significantly reduce its likelihood, (1) apply lubricant to bolts, preferably an anti-seize lubricant, available at auto parts stores, (2) shade hardware prior to installation, and (3) avoid spinning on nuts at high speed. See Installation Supplement 910, *Galling and Its Prevention*, at www.unirac.com.



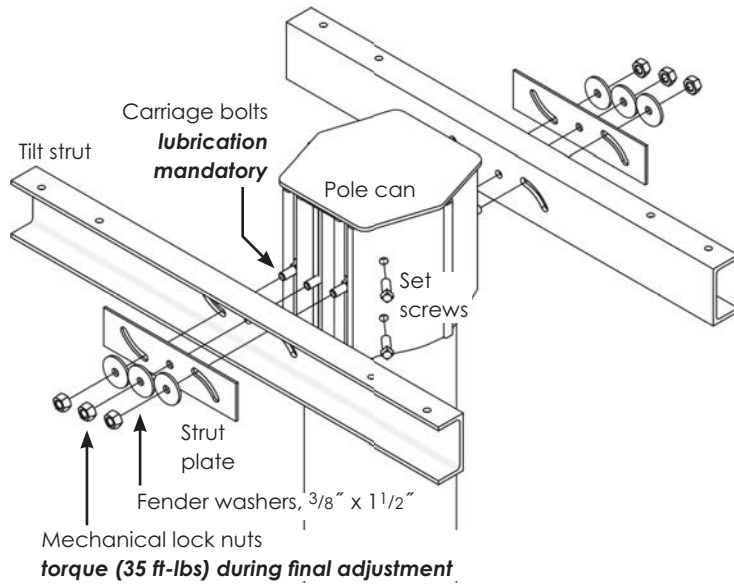

Attach struts to pole can

On each side of the can, install the center $\frac{3}{8}$ -inch carriage bolt, pushing it through the square hole from inside the pole can. (The can may now be placed on the pole and set screws finger tightened *or* assembly may continue off pole, depending on installer preference.) Slide the remaining four carriage bolts into the slots on both sides of the can.

Carriage bolts must be lubricated with anti-seize to achieve design bolt tension during final adjustment.



Loosely secure strut plates and fender washers with the mechanical lock nuts. Do not tighten the lock nuts until final adjustment.

Tilt struts can be tilted in one direction only. Verify that they are installed to tilt toward the noon sun. If not, reverse the position of the two tilt struts.

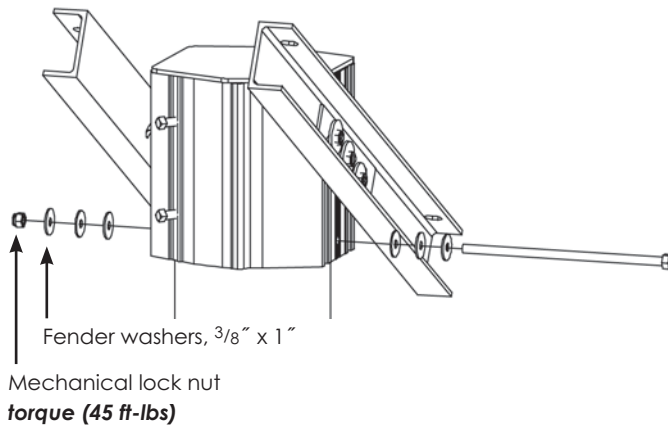

Secure pole can

This step may be taken immediately after tilt strut assembly or following final adjustment, depending on installer preference.

Using a $\frac{3}{16}$ -inch drill, make pilot holes through the two sides of the can and the Schedule 40 mounting pole. Expand the holes with a $\frac{13}{32}$ -inch drill.

With three washers on each side, pass the $\frac{3}{8}$ x 9-inch Grade 8 bolt through can an pole and secure with the remaining $\frac{3}{8}$ -inch mechanical lock nut. Torque to 45 foot pounds.

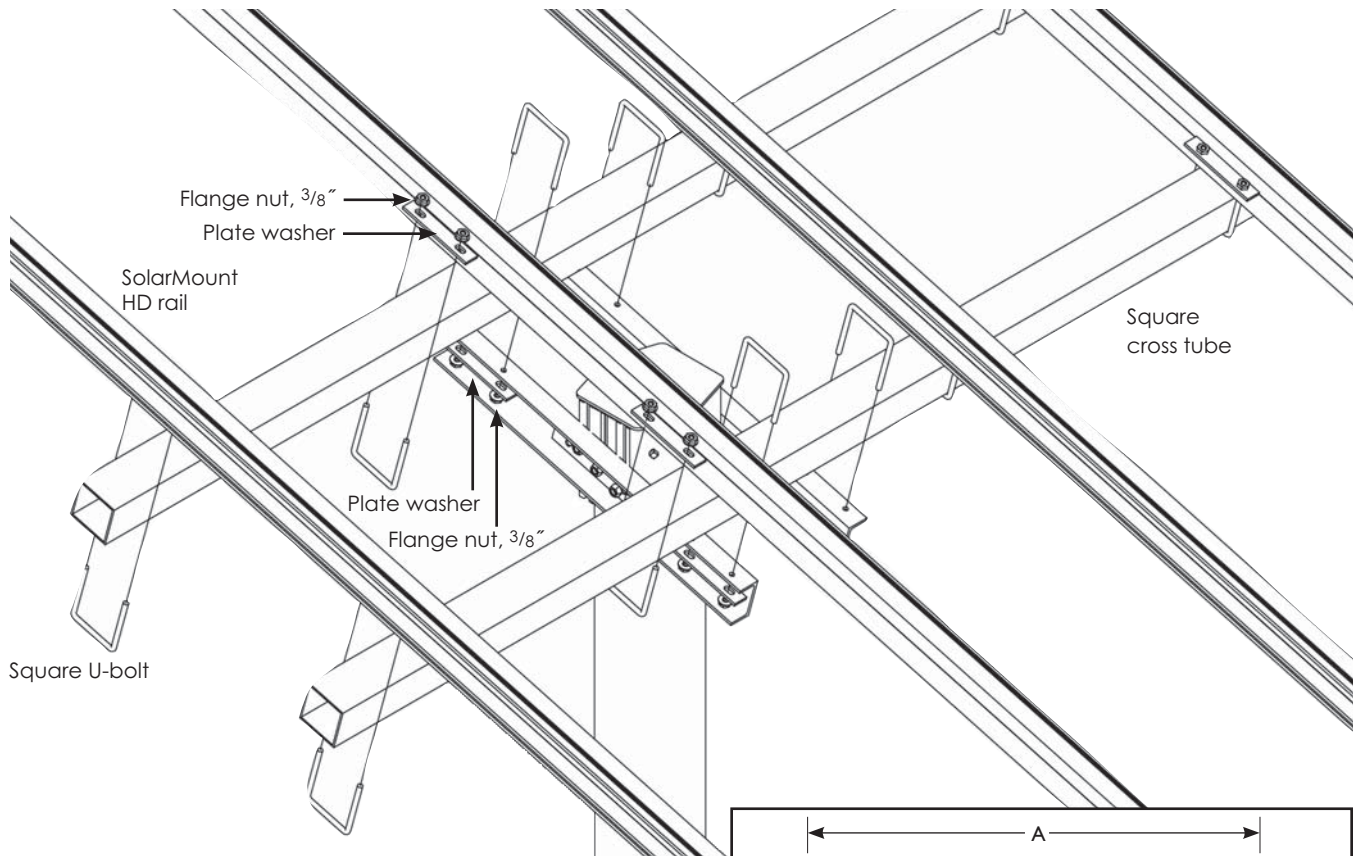

Attach cross tubes and rails

Attach square cross tube to tilt struts using four square U-bolts and U-bolt plates, secured with $\frac{3}{8}$ -inch flange nuts. Torque to 30 foot-pounds (40 newton-meters).

Add rails using the remaining eight sets of square U-bolts and U-bolt plates. Make sure the rails are parallel and that the two outer rails are equidistant from the center of the cross pipe. Space the inner rails following the illustration at right. Finger tighten $\frac{3}{8}$ -inch flange nuts on U-bolts.

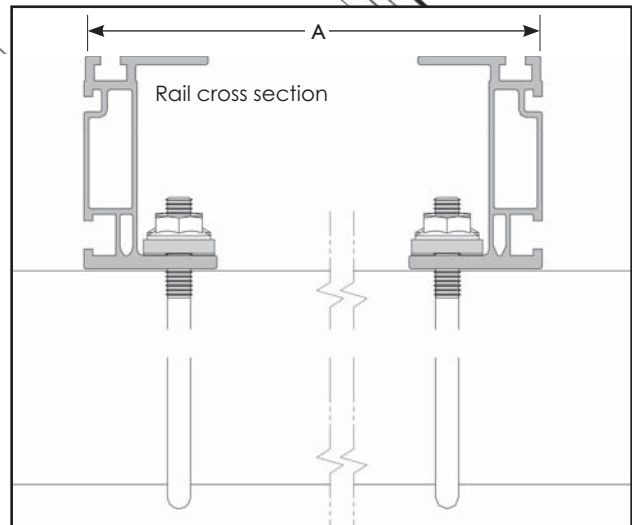

For each pair of rails, the distance (A) between the rails' outer edges equals the distance between the centers of the module mounting holes minus one inch (2.5 cm).

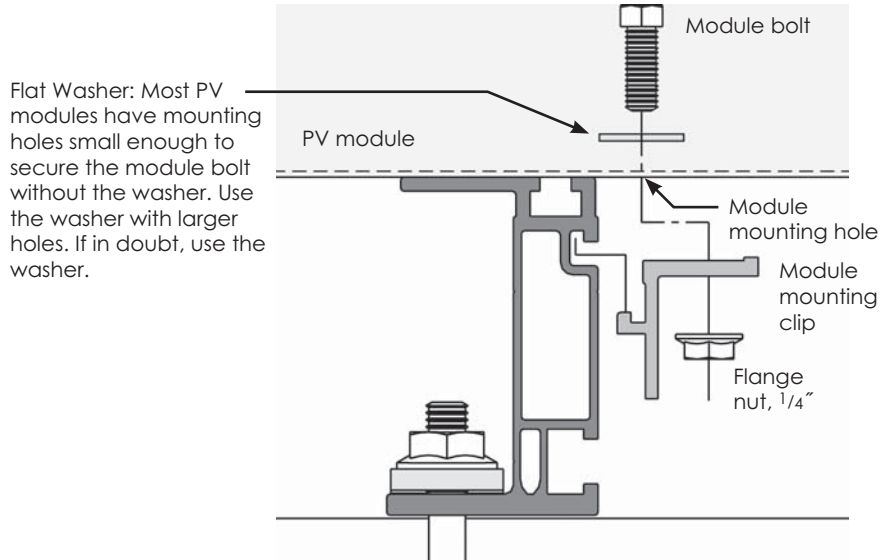

Flat Washer: Most PV modules have mounting holes small enough to secure the module bolt without the washer. Use the washer with larger holes. If in doubt, use the washer.

Install modules

Secure each PV module using four clips. Be sure modules are centered along the length of the rail. Initially finger tighten 1/4-inch flange nuts. When all modules are in place and aligned, torque 1/4-inch flange nuts to 15 foot-pounds (20 newton-meters).

When modules are centered along the rails and secure, tighten the 3/8-inch flange nuts holding the rails to the square cross tubes. Torque to 30 foot-pounds (40 newton-meters).

Final adjustment

With an assistant supporting the rack, loosen the lock nuts on the tilt struts. Bring the rails level to allow clear access to the 3/8-inch set screws on the pole can.

Loosen the set screws and adjust the direction of the entire array on the pole. Once satisfied with the array's alignment, use a 7/16-inch 12-point socket wrench and torque all four set screws to 25 foot-pounds (32 newton-meters).

Adjust the array to the desired tilt angle. Torque lock nuts to 35 foot-pounds (46 newton-meters).

After all six lock nuts are torqued, repeat the torquing procedure at least once.



⚠ Mounting pole guidelines for UniRac PV PoleTops®

The installer is solely responsible for use of these general guidelines. The following variances can affect your installation:

- The required diameter and depth of the hole depend on soil type. Sandy soil, for example, requires more concrete.
- The diameter and depth of the hole should also be increased wherever wind speeds exceed those listed in the table below, particularly if the site is open and unprotected. **Note the wind loading and exposure assumptions in the table note below.**
- Poles taller than 6 feet (1.8 meters) require that the depth of the hole be increased.

If in doubt, consult a professional civil engineer who is familiar with local soil conditions and wind loading requirements.

1. Dig the hole at least 4 inches (10 cm) deeper than required under “In-ground pole depth” in the table below. Fill the extra depth with gravel to allow water drainage.
2. Take some measure to prevent the pole from turning in the concrete during high winds.
3. Brace the pole so that it is plumb in the hole. Pour concrete around it, filling the hole to ground level. Add an inch or two (3 to 5 cm) of extra concrete above the hole. Trowel the concrete so that it slopes up to the pole (see table illustration).
4. Allow the concrete to set up for at least 24 hours before installing your PV Poletop.

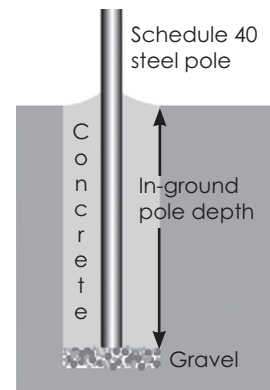

Mounting Pole Requirements

Imperial					Metric				
Total module area	Design wind speed	Hole diameter	In-ground pole depth	Concrete volume	Total module area	Design wind speed	Hole diameter	In-ground pole depth	Concrete volume
60 sq. ft.	90 mph	24 in.	46 in.	12 cu. ft.	6 sq. m	150 km/h	60 cm	120 cm	0.34 m ³
60 sq. ft.	120 mph	30 in.	52 in.	21 cu. ft.	6 sq. m	200 km/h	70 cm	155 cm	0.59 m ³
70 sq. ft.	90 mph	24 in.	54 in.	14 cu. ft.	7 sq. m	150 km/h	60 cm	140 cm	0.39 m ³
70 sq. ft.	120 mph	30 in.	60 in.	24 cu. ft.	7 sq. m	200 km/h	70 cm	175 cm	0.67 m ³
80 sq. ft.	90 mph	24 in.	60 in.	16 cu. ft.	8 sq. m	150 km/h	60 cm	160 cm	0.45 m ³
80 sq. ft.	120 mph	30 in.	68 in.	28 cu. ft.	8 sq. m	200 km/h	70 cm	205 cm	0.78 m ³
90 sq. ft.	90 mph	24 in.	68 in.	18 cu. ft.	9 sq. m	150 km/h	60 cm	175 cm	0.50 m ³
90 sq. ft.	120 mph	30 in.	76 in.	31 cu. ft.	9 sq. m	200 km/h	70 cm	225 cm	0.87 m ³
100 sq. ft.	90 mph	24 in.	76 in.	20 cu. ft.	11 sq. m	150 km/h	60 cm	215 cm	0.60 m ³
100 sq. ft.	120 mph	30 in.	82 in.	34 cu. ft.	11 sq. m	200 km/h	80 cm	200 cm	1.00 m ³

Assumptions: The pole extends no more than 6 feet (1.8 meters) above ground. Design wind speeds assume 29 psf wind force at 90 mph (150 km/h) and 51 psf wind force at 120 mph (200 km/h), which correspond to Exposure Category C of the International Building Code, terrain that is flat and generally open extending one-half mile (800 meters) or more from the site in any quadrant.

High wind brace

A high wind brace is standard with all Series 5014 PV PoleTops. For all Series 5004 PV PoleTops, it may be installed as an option (item no. 990365).

Slide the heads of the $\frac{3}{8} \times \frac{3}{4}$ -inch hexhead bolts into the footing slots of the SolarMount HD rails. Attach L-feet 6 to 12 inches from the ends of the rails and finger tighten flange nuts. Attach rail strut with four of the $\frac{3}{8} \times 1\frac{1}{4}$ -inch bolts and strut nuts. Finger tighten.

Attach pole bracket to pole. Finger tighten flange nuts.

Attach leg struts to pole bracket and rail strut with remaining $\frac{3}{8} \times 1\frac{1}{4}$ -inch hexhead bolts and strut nuts. Place leg struts just outside the inner rails. Finger tighten.



Adjust to make leg struts parallel to the ground. Be sure that L-feet are vertical.

Torque all $\frac{3}{8}$ -inch hardware to 30 foot-pounds (40 newton-meters).

If desired for aesthetics, trim rail strut and leg struts.

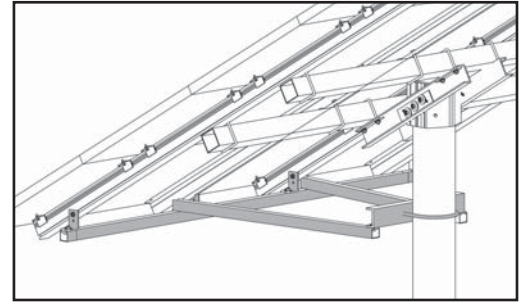

Attach leg struts parallel to the ground just outside the inner rails

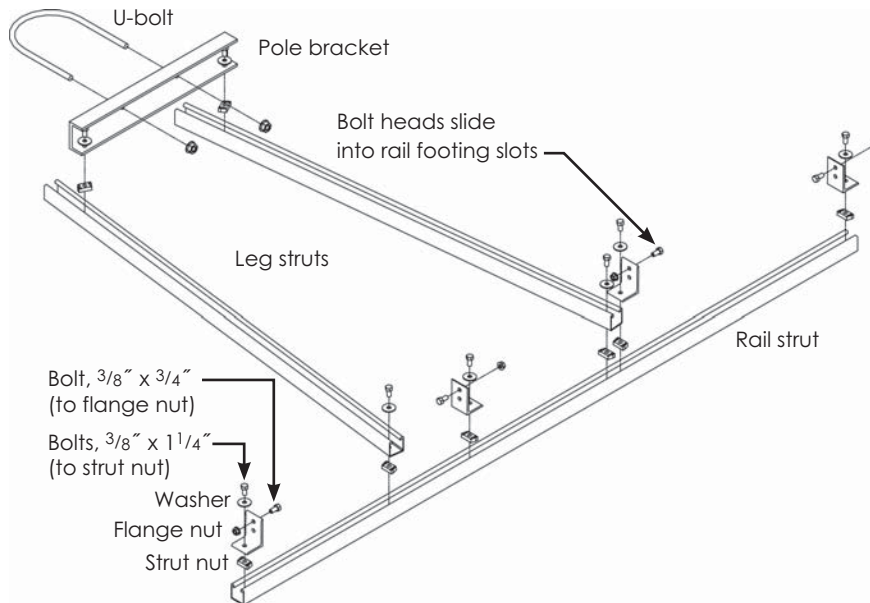

10 year limited Product Warranty

UniRac, Inc., warrants to the original purchaser ("Purchaser") of product(s) that it manufactures ("Product") at the original installation site that the Product shall be free from defects in material and workmanship for a period of ten (10) years, from the earlier of 1) the date the installation of the Product is completed, or 2) 30 days after the purchase of the Product by the original Purchaser. This Warranty does not cover damage to the Product that occurs during its shipment, storage, or installation.

This Warranty shall be VOID if installation of the Product is not performed in accordance

with UniRac's written installation instructions, or if the Product has been modified, repaired, or reworked in a manner not previously authorized by UniRac IN WRITING, or if the Product is installed in an environment for which it was not designed. UniRac shall not be liable for consequential, contingent or incidental damages arising out of the use of the Product by the Purchaser under any circumstances.

If within the specified Warranty period the Product shall be reasonably proven to be defective, then UniRac shall repair or replace the defective Product, or any part thereof,

in UniRac's sole discretion. Such repair or replacement shall completely satisfy and discharge all of UniRac's liability with respect to this limited Warranty. Under no circumstances shall UniRac be liable for special, indirect or consequential damages arising out of or related to use by Purchaser of the Product.

Manufacturers of related items, such as PV modules and flashings, may provide written warranties of their own. UniRac's limited Warranty covers only its Product, and not any related items.



THE STANDARD IN PV MOUNTING STRUCTURES™