

PV POLETOPS™

Series 5003 Double Row 4-Inch Pole Top with SolarMount® HD Rails *Installation Manual 504.3*

U.S. Des. Patent No. D496,249S. Other patents pending.

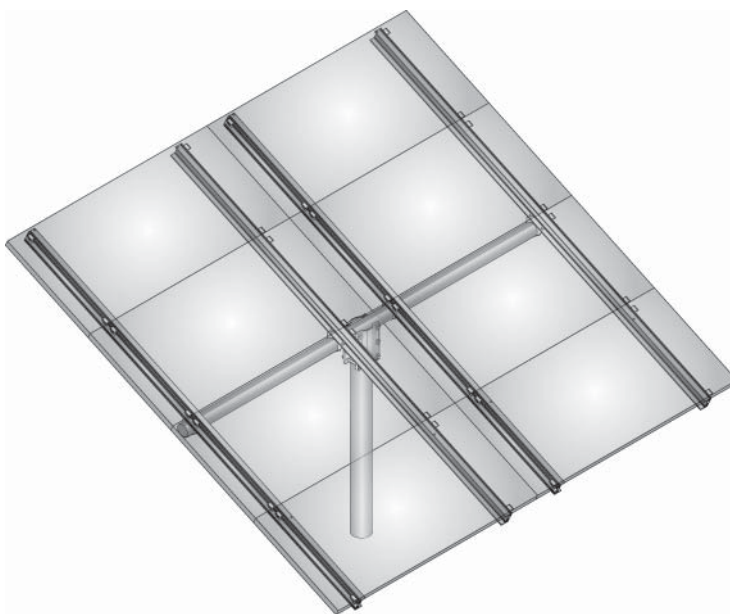

Thank you for purchasing a UniRac. Please review this manual completely before proceeding.

This rack is intended for a 4-inch (100 mm) Schedule 40 steel pole, outside diameter 4.500 inches (114.3 mm).

Assembly order is not critical. Work from the pole outward or attach PV modules to rails before mounting the array to the pole.



The installer is solely responsible for:

- complying with all applicable building codes, including any that supersede these instructions;
- pole installation appropriate to local wind and soil conditions;
- using only UniRac parts and installer-supplied parts as specified by UniRac (substitution of parts will void the warranty);
- installing all electrical aspects of the PV array.

Parts List (Parts are illustrated in exploded views pp. 2–4.)

Part	Qty.	Wrench size	Recommended torque, ft-lbs (N-m)
SolarMount rail	4		
Cross pipe, 3"	1		
Pole clamp	2		
Pole cap	1		
Pole clamp bolt, 7/16" x 5"	6	5/8"	30 (40)
Lock washer, 7/16"	6		
Nut, 7/16"	6	9/16"	30 (40)
Saddle	4		
U-bolt, 3/8"	4		
Flange nut, 3/8"	8	9/16"	30 (40)
Module mounting clip	4*		
Module bolt, 1/4"	4*	7/16"	15 (20)
Flat washer, 1/4"	4*		
Flange nut, 1/4"	4*	7/16"	15 (20)



Stainless steel hardware can seize up, a process called galling. To significantly reduce its likelihood, (1) apply lubricant to bolts, preferably an anti-seize lubricant, available at auto parts stores, (2) shade hardware prior to installation, and (3) avoid spinning on nuts at high speed. See Installation Supplement 910, *Galling and Its Prevention*, at www.unirac.com.

*Per module to be mounted. Series 5003 racks include clips and hardware to mount from 4 to 10 modules, depending on the model number.

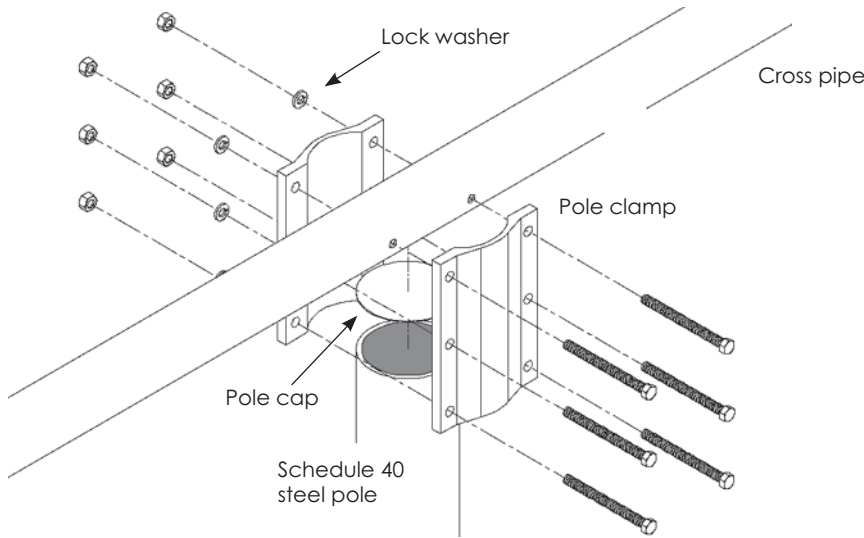

Attach cross pipe

Assemble pole clamps to cross pipe using 7/16-inch hardware. Finger tighten initially, then torque to 30 foot-pounds (40 newton-metres) before adding rails.

Mounting pole guidelines for UniRac PV PoleTops



The installer is solely responsible for use of these general guidelines. The following variances can affect your installation:

- The required diameter and depth of the hole depend on soil type. Sandy soil, for example, requires more concrete.
- The diameter and depth of the hole should also be increased wherever wind speeds exceed those listed in the table below, particularly if the site is open and unprotected. **Note the wind loading and exposure assumptions in the table note below.**
- Poles taller than 6 feet (1.8 metres) require that the depth of the hole be increased.

If in doubt, consult a professional civil engineer who is familiar with local soil conditions and wind loading requirements.

1. Dig the hole at least 4 inches (10 cm) deeper than required under “In-ground pole depth” in the table below. Fill the extra depth with gravel to allow water drainage.
2. Take some measure to prevent the pole from turning in the concrete during high winds.
3. Brace the pole so that it is plumb in the hole. Pour concrete around it, filling the hole to ground level. Add an inch or two (3 to 5 cm) of extra concrete above the hole. Trowel the concrete so that it slopes up to the pole (see table illustration).
4. Allow the concrete to set up for at least 24 hours before installing your PV Poletop.

Mounting Pole Requirements

Imperial					Schedule 40 steel pole	Metric				
Total module area	Design wind speed	Hole diameter	In-ground pole depth	Concrete volume		Total module area	Design wind speed	Hole diameter	In-ground pole depth	Concrete volume
40 sq. ft.	90 mph	18 in.	54 in	8 cu. ft.		4 sq. m	150 km/h	50 cm	115 cm	0.22 m ³
40 sq. ft.	120 mph	24 in.	54 in	14 cu. ft.		4 sq. m	200 km/h	60 cm	140 cm	0.39 m ³
50 sq. ft.	90 mph	18 in.	56 in	10 cu. ft.		5 sq. m	150 km/h	60 cm	100 cm	0.28 m ³
50 sq. ft.	120 mph	24 in.	66 in	17 cu. ft.		5 sq. m	200 km/h	60 cm	170 cm	0.48 m ³
60 sq. ft.	90 mph	24 in.	46 in.	12 cu. ft.		6 sq. m	150 km/h	60 cm	120 cm	0.34 m ³
60 sq. ft.	120 mph	30 in.	52 in.	21 cu. ft.		6 sq. m	200 km/h	70 cm	155 cm	0.59 m ³
70 sq. ft.	90 mph	24 in.	54 in.	14 cu. ft.		7 sq. m	150 km/h	60 cm	140 cm	0.39 m ³
70 sq. ft.	120 mph	30 in.	60 in.	24 cu. ft.		7 sq. m	200 km/h	70 cm	175 cm	0.67 m ³

Assumptions: The pole extends no more than 6 feet (1.8 metres) above ground. Design wind speeds assume 29 psf wind force at 90 mph (150 km/h) and 51 psf wind force at 120 mph (200 km/h), which correspond to Exposure Category C of the International Building Code, terrain that is flat and generally open extending one-half mile (800 meters) or more from the site in any quadrant.

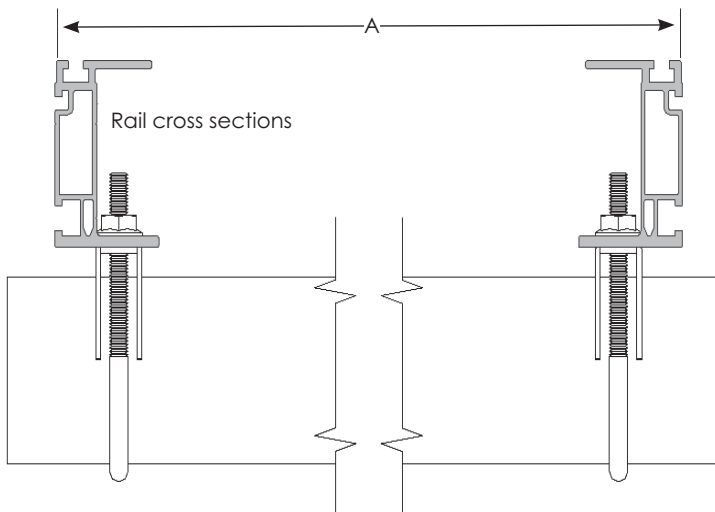
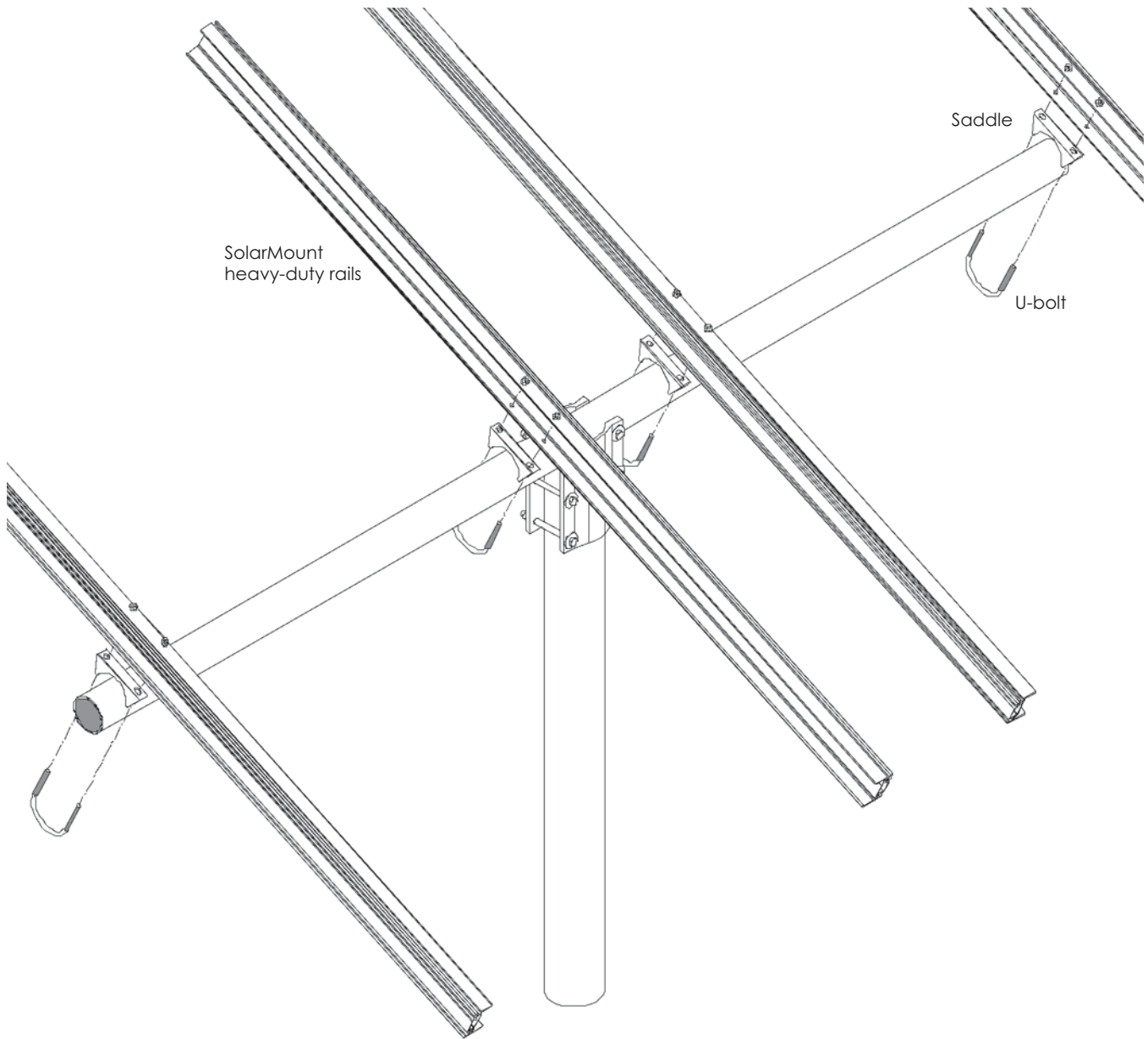

Distance between rails' outer edges (A) equals distance between module mounting-hole centers minus 1 inch (2.5 cm).

Secure rails

Add rails, making sure that rails are parallel, equidistant from the center of the cross pipe, and tilting slightly. (This is not intended to be the final tilt angle.) Tighten the U-bolt flange nuts enough to keep the rails in place during module installation, when the assembly will be temporarily out of balance.

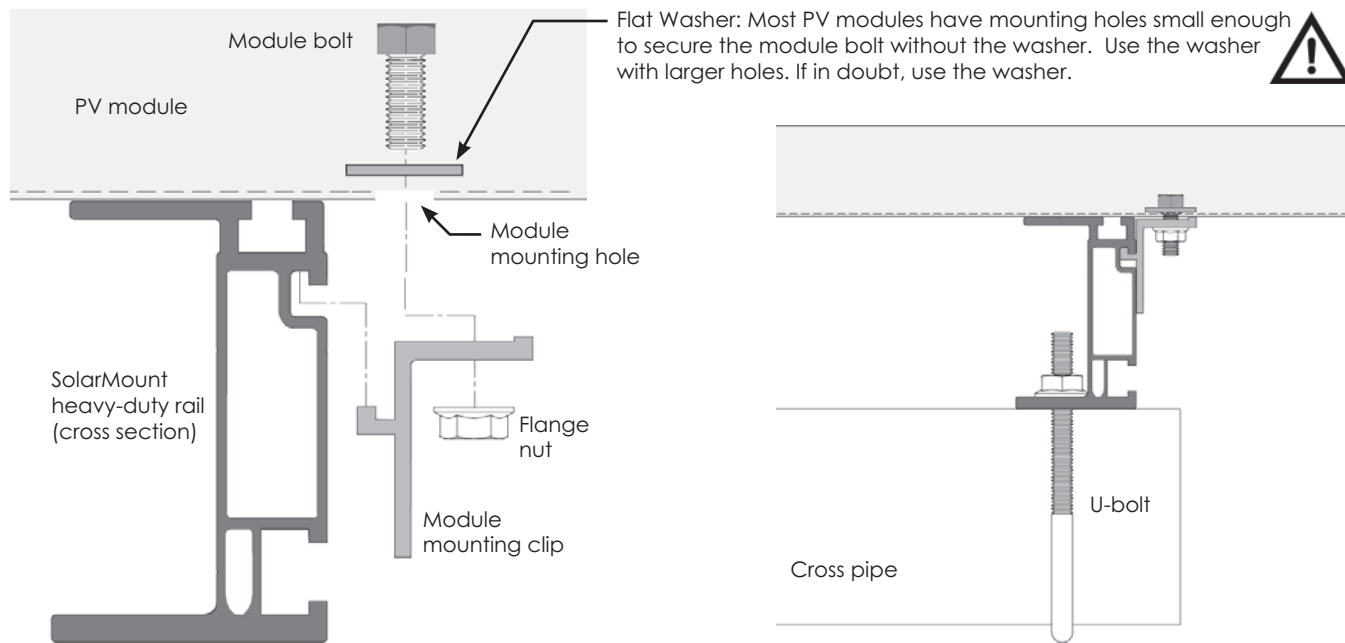

Install modules

Secure each PV module using four clips, two per rail. To ensure a balanced array, center modules along the rails. Initially finger tighten 1/4-inch flange nuts. When all modules are in place, torque 1/4-inch flange nuts to 15 foot-pounds (20 newton-metres).

Final adjustment

When the array is fully assembled, loosen the U-bolt flange nuts enough to adjust the array's tilt to the desired angle. When satisfied, torque the flange nuts to 30 foot-pounds (40 newton-metres).

The 7/16-inch nuts securing the pole clamps can be loosened, allowing the entire array to turn on the pole. Be sure to retorque the nuts to 30 foot-pounds (40 newton-metres) after final adjustment.

10 year limited Product Warranty

UniRac, Inc., warrants to the original purchaser ("Purchaser") of product(s) that it manufactures ("Product") at the original installation site that the Product shall be free from defects in material and workmanship for a period of ten (10) years, from the earlier of 1) the date the installation of the Product is completed, or 2) 30 days after the purchase of the Product by the original Purchaser. This Warranty does not cover damage to the Product that occurs during its shipment, storage, or installation.

This Warranty shall be VOID if installation of the Product is not performed in accordance

with UniRac's written installation instructions, or if the Product has been modified, repaired, or reworked in a manner not previously authorized by UniRac IN WRITING, or if the Product is installed in an environment for which it was not designed. UniRac shall not be liable for consequential, contingent or incidental damages arising out of the use of the Product by the Purchaser under any circumstances.

If within the specified Warranty period the Product shall be reasonably proven to be defective, then UniRac shall repair or replace the defective Product, or any part thereof,

in UniRac's sole discretion. Such repair or replacement shall completely satisfy and discharge all of UniRac's liability with respect to this limited Warranty. Under no circumstances shall UniRac be liable for special, indirect or consequential damages arising out of or related to use by Purchaser of the Product.

Manufacturers of related items, such as PV modules and flashings, may provide written warranties of their own. UniRac's limited Warranty covers only its Product, and not any related items.

