

THE NEW VALUE FRONTIER



KC50T-1

HIGH EFFICIENCY POLYCRYSTALLINE PHOTOVOLTAIC MODULE



Kyocera is "ISO9001" certified and registered.

TUVdotCOM Internet platform for tested quality and service ID 0000007146.

HIGHLIGHTS OF KYOCERA PHOTOVOLTAIC MODULES

Kyocera's advanced cell processing technology and automated production facilities produce a highly efficient polycrystalline photovoltaic module.

The conversion efficiency of the Kyocera solar cell is 16%.

These cells are encapsulated between a tempered glass cover and a pottant with back sheet to provide efficient protection from the severest environmental conditions.

The entire laminate is installed in an anodized aluminum frame to provide structural strength and ease of installation.

APPLICATIONS

Grid-Connected Systems

- Residential Solar Power Systems
- Public and Industrial Solar Power Systems

Stand-Alone Solar Power Systems for

- Villages in remote areas
- Homes and summer cottages
- Microwave / Radio repeater stations
- Medical facilities in rural areas

- Emergency communication
- Water quality and environmental data monitoring
- Drinking water and livestock water pumping
- Small-scale irrigation pumping
- Cathodic protection
- Aviation obstruction lights
- Environmental data monitoring
- Railway signals
- Street lighting
- Small-scale desalination

LIMITED PERFORMANCE WARRANTY

※2 years limited warranty on material and workmanship

※25 years limited warranty on power output.

(Long term output warranty shall guarantee that loss of output is not more than 10% of the minimum warranty value of the product specifications within 12 years and is not more than 20% within 25 years after the purchase of the product by customer. The output values shall be those measured under Kyocera standard measurement conditions. Regarding the warranty conditions in detail, please refer to Warranty issued by Kyocera.)

ELECTRICAL CHARACTERISTICS

Current-Voltage characteristics of Photovoltaic Module KC50T-1 at various cell temperatures

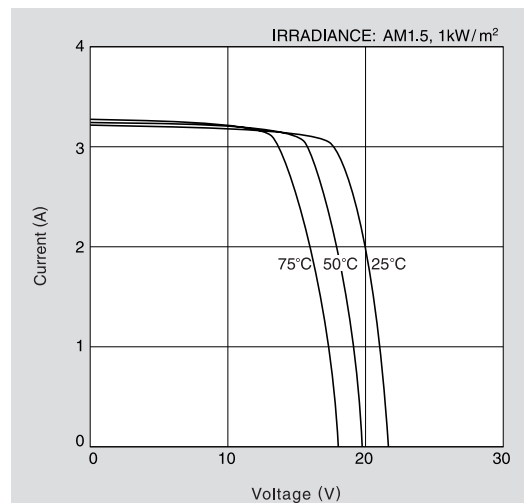

Current-Voltage characteristics of Photovoltaic Module KC50T-1 at various irradiance levels

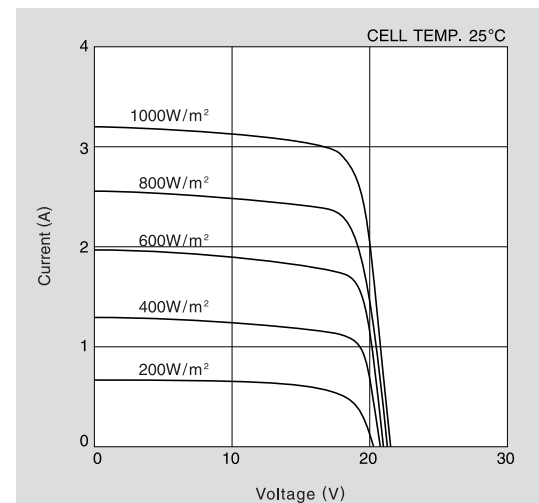

MODEL
KC50T-1

Physical Specifications

(Unit : mm)

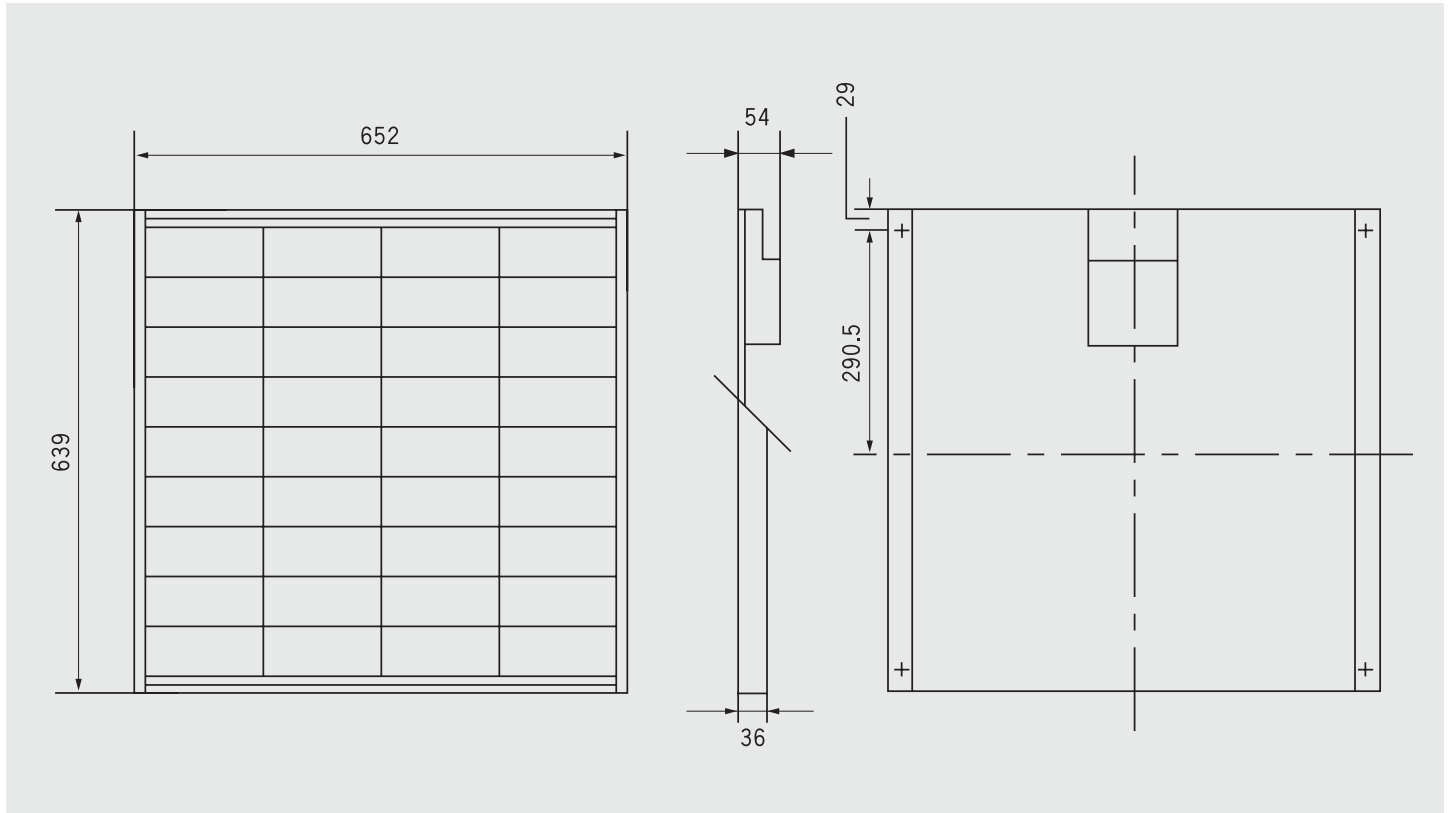

Specifications

Electrical Data		
Maximum Power(Pmax)	[W]	54
Tolerance	[%]	+15/-5
Maximum Power Voltage	[V]	17.4
Maximum Power Current	[A]	3.11
Open Circuit Voltage (Voc)	[V]	21.7
Short Circuit Current (Isc)	[A]	3.31
Temp. coefficient of Voc	[V/°C]	-8.21×10 ⁻²
Temp. coefficient of Isc	[A/°C]	1.33×10 ⁻³
NOCT	[°C]	47
Max System Voltage	[V]	750

Dimension		
Length	[mm]	639
Width	[mm]	652
Depth without box	[mm]	36
Weight	[kg]	5.0

Cells	
Number per module	36
Cell Technology	Polycrystalline
Cell Shape	Rectangular

Note : The electrical specifications are under test conditions of Irradiance of 1kw/m², Spectrum of 1.5 air mass and cell temperature of 25°C.
Kyocera reserves the right to modify these specifications without notice.

Please contact our office to obtain details without hesitation.



KYOCERA Corporation

KYOCERA Corporation Headquarters

CORPORATE SOLAR ENERGY DIVISION
6 Takeda Tobadono-cho
Fushimi-ku, Kyoto
612-8501 Japan
Phone:(81)75-604-3476 Telefax:(81)75-604-3475
http://www.kyocera.com

● **KYOCERA Fineceramics GmbH**

Fritz Muller strasse 107, D-73730 Esslingen, Germany
Phone:(49)711-9393417 Telefax:(49)711-9393450
http://www.kyocerasolar.de/

● **KYOCERA Asia Pacific Pte. Ltd.**

298 Tiong Bahru Road, #13-03/05
Central Plaza, Singapore 168730
Phone:(65)271-0500 Telefax:(65)271-0600

● **KYOCERA Solar, Inc.**

7812 East Acoma Drive
Scottsdale, AZ 85260, USA
Phone:(1)480-948-8003 or (800)223-9580 Telefax:(1)480-483-6431
http://www.kyocerasolar.com

● **KYOCERA(Tianjin) Sales & Trading Corporation**

Binjiang International Hotel 1106
105 Jianshe Road Heping Dist. Tianjin China
Tel:(22)2331-8590 Fax:(22)2330-6276